

Plate de Pays Aesthetics and Tradition



BMI **MONIER**

CLAY TILE
Flat Tile

monier.fr

Plate de Pays

- Easy hanging bar the implementation and stability of the tile
- Positioning marker for ease of installation
- Shaded colors to find the aesthetics of your old roofs

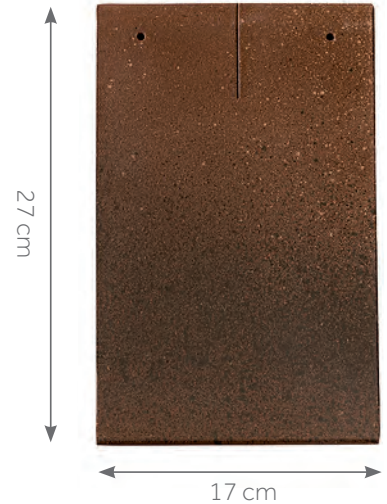

Overall dimensions in cm



TECHNICAL CHARACTERISTICS

Type	Clay flat tile
Number of tiles per m ²	59 to 65 depending on gauge
Gauge	10 to 9 cm depending on minimum overlap 7 to 9 cm
Linear cover	≈ 17.2
Linear meter of battens/m ²	10 to 11 ml
Gutter ventilation section	0 cm ² /ml
Tile interlocking category	Category G0
Unit weight	≈ 1.18 kg
Weight per m ²	69,6 to 76,7 kg
Number of tiles per pallet	864
Weight per pallet	1020 kg
Production site	Roumazières
Laying	Broken bond
Silicone product	An additive is required for sealing
Product standard	NF EN 1304
Application standard	NF P 31-204 [DTU 40.23]
Minimal gradient*	60 % / 30°96' (Zone 1, sheltered site with underlay and minimal overlap of 8 cm)

* See the gradient table on the back of this document.

PRESCRIPTION RECOMMENDATION

The tile will be in terracotta, family Flat tiles from 59 to 65 m² (depending on gauge); it will have a strip on the whole of its width allowing an optimal grip, of type PLATE DE PAYS from MONIER or similar.

It will be laid broken bond, on battens according to the standard of the NF application NF P 31-204 [DTU 40.23]

Its installation will be carried out using all the parts specially designed for dry mortarless laying of ridges and edges as specified in the DTU.

GUARANTEES

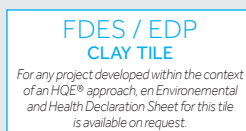
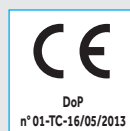

COLOURS



Oak Earth (2U)



Antique Red (7E)



Antique Ochre (1U)



As a pioneer in the development of complete roofing systems, Monier has designed an innovative range according to the rules of the trade: terracotta and concrete tiles, roofing components and external thermal insulation. The professionals at Monier are authentic in their relationships and offer support and advice for their customers.

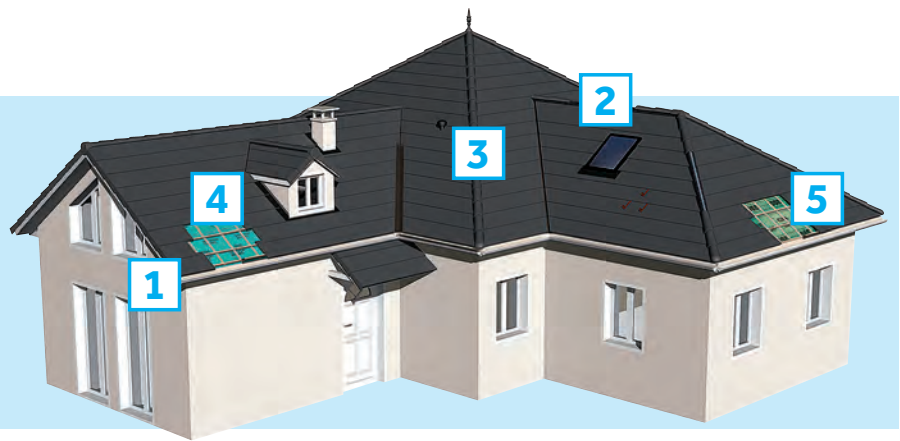

1 TRANSVERSE DISTRIBUTION ACCORDING TO EDGE ASSEMBLY

The fittings range offers choice of two verge finishes:

- half verge tile with return,
- tile-and-a-half tile.

Both tiles are alternated with a normal tile to create a staggered joint.

A neoprene washer is used for fastening.

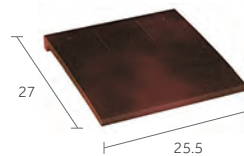
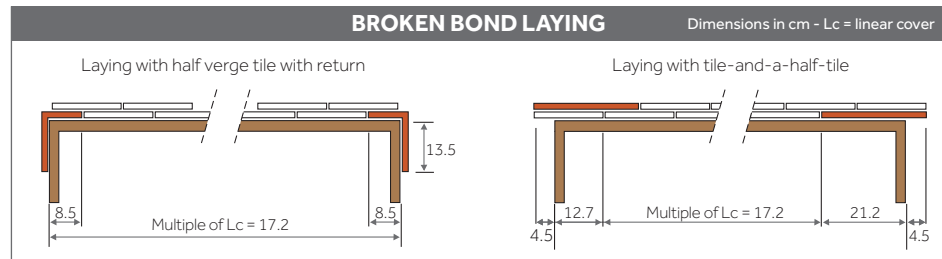

Tile-and-a-half tile

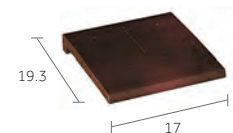

Short tile

2 RIDGES, HIPS & END CAPS

The range enables 2 hip finishes:

- Corner hip finish,
- Tige de botte hip finish.

Three different ridges can be used up to the laying customs:

- Semi-round ridge tile 33,
- Semi-round end-to-end ridge tile 30,
- Angular end-to-end ridge tile 33.

The tile and a half tile enables satisfactory cutting sizes. This system enables the ridge and hip to adapt to the nature movements of the roof. The ridge courses are made by cutting the tiles closest to the ridge board. All ridges and hips must be fastened with a screw.

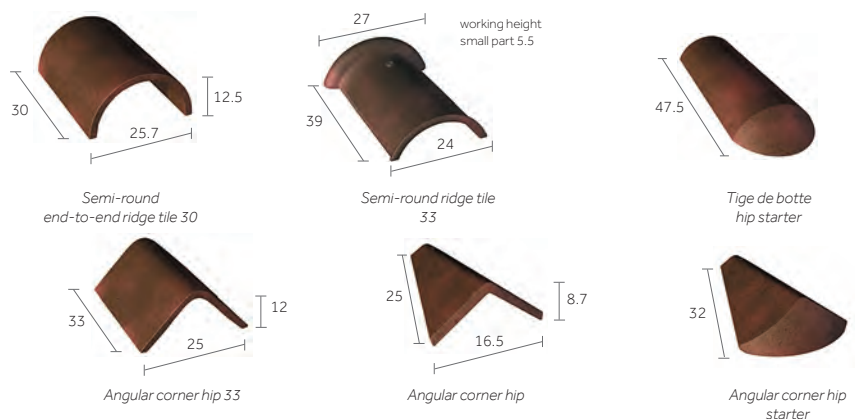

3 AERATION & VENTILATION

The underside of the tile and their support must be ventilated. This ensures overall correct behaviour of roofing components over time.

The use of ventilation tiles is recommended at the upper and lower parts of the roof.

The total of ventilation openings must be distributed equally between lower part of the roof slope and near the ridge.

Humid or foul air outlets from the ventilation or extraction of living areas by forced mechanical ventilation or other systems, must be routed out of attic spaces.

The ventilation sections mentioned take into account values standardized by the latest building code regulations.

Preferably, exhaust tiles are to be located at the top of the slope.

The sections mentioned values standardized by the last revisions of DTU series 40.2 ...



Through tile and lantern 5 elements (Ø util 120 mm)

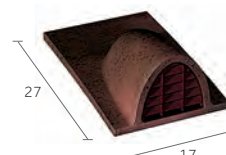

Ventilation tile with grid (opening 20 cm²)

	Type of attic	Total ventilation section ^(a)
Roof space not fitted out without barrier		$S = 1/5000$
Roof space not fitted out with barrier		$S1 = 1/5000$ $S2 = 1/3000^{(b)}$
Insulated sloping section without barrier		$S = 1/3000$
Insulated sloping section with barrier		$S1 = 1/5000$ $S2 = 1/3000$
Insulated sloping section with barrier highly permeable to water vapour and presence of continuous, independent vapour barrier		$S = 1/5000$

S marks the section of openings related to the volume to be ventilated between insulation and roofing elements.
S1 marks the section of openings related to the volume to be ventilated between barrier and roofing elements.
S2 marks the section of openings related to the volume to be ventilated between insulation and barrier ventilated underneath.

The use of an HPV screen necessarily implies the implementation of a continuous vapor barrier on the underside of the insulation.

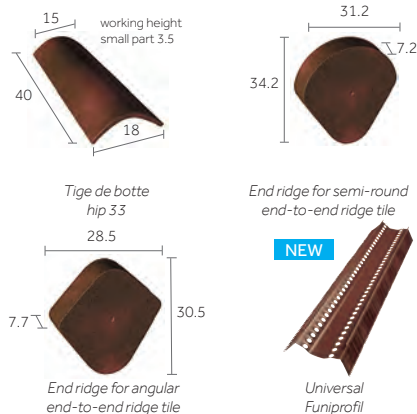
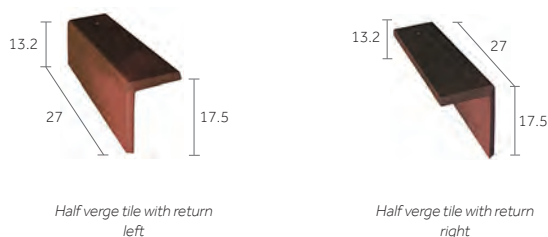

MONIER RECOMMENDS DRY ASSEMBLY WITH VENTILATED CLOSURE MATERIAL ON A ROLL.

The dry assembly of a ridge/hip is quick to implement, guarantees ventilation and allows for later intervention.

This system allows the ridge and the hip to adapt to the roof's natural movement.

WAKAFLEX® is the universal waterproofing solution for the treatment of individual roof areas. It is very easy to use and can be applied cold without welding.



DISTRIBUTED OVER THE LENGTH OF THE SLOPING SECTION

Laying of a ventilated eaves batten (ventilation 199 cm²/ml) on the tilt batten guarantees linear ventilation in the lower section in accordance with the DTU's recommendations.

A short tile is needed in the sewer under the first tile and the ridge on the last tile. All tiles on the eaves must be fastened. Please refer to the DTU in force. (DTU 40.23).

The dimension GD mentioned by Monier will vary according to several parameters : height, gauge, roof pitch and overhang d, and may be adjusted to achieve the required overlap.

The interlocking part (water flow) must to be taken into account when defining dimensions GD and overhang distance (d).

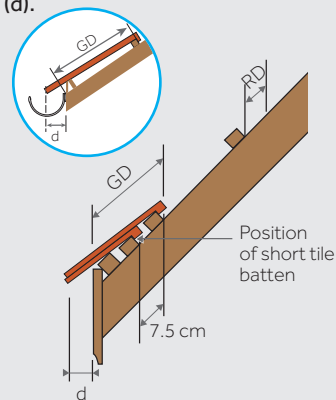

RD = Ridge batten distance = 4 cm

GD = Distance from batten to gutter

This dimension is to be adjusted according to the projection of the gutter tile (dimension d) and the roof gradient.

d = 8 to 6 cm. The gutter projection is determined according to the type of gutter. The tile nib must be aligned ± 1 cm with the gutter.



Ventilated eaves batten without comb (L 1 m - H 30 mm)

LAYING TILES IN A SQUARE LAYOUT

The attachments must be compliant with the requirements described in paragraph 4.3 of the D.T.U. 40.23.

The regions in question are the ones on the wind map (reference NF EN 1991-1-4/NA).

The sites exposed to the winds shown on the wind map correspond to the situations defined in Appendix B of the D.T.U. 40.23.

All edging and guttering tiles are attached.

For violent winds, Monier recommends going beyond the DTU recommendation and therefore fastening all tiles.

4 UNDERLAYS

The underlays are mainly for:

- to ensure a complementary seal and protect the underlying premises against the penetration of powdery snow, dust, pollen, soot and water infiltration,
- to preserve the performance and the durability of the insulation in under face,
- allow to lower the slopes minimum cover when the DTUs provide for it.

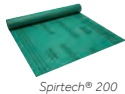

For more information, consult the Monier General Catalog

5 OUTDOOR INSULATION SARKING

The sarking, thermal insulation process by the outside dedicated to the attic or developable, is to enhance the roof to insert a thin layer of insulation.

Monier offers a complete range:

- CLIMA FIRST®, quality at the best price,
- CLIMA COMFORT®, the high performance range.

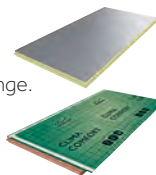

For more information, consult the Monier General Catalog

THE ADVICE OF THE PRO

To ensure the tightness of the tiles in the first row, use the short tiles in duplicate.
For the last row (ridge), lay a line of short tiles. Take advantage of the landmark positioning of the tile which facilitates its implementation.
Leave a space between two tiles to avoid contact and facilitate installation.

THE REGULATIONS

MINIMUM PITCH TABLE IN %

MINIMUM ACCEPTABLE PITCHES IN % (WITH UNDERLAY)

	Minimal overlap in cm	Sheltered site	Normal site	Exposed site
Zone 1	≥ 8	60	70	85
	≥ 7	70	80	95
Zone 2	≥ 8	60	80	95
	≥ 7	70	85	105
Zone 3	≥ 9	70	85	100
	≥ 8	80	95	110

MINIMUM ACCEPTABLE PITCHES IN % (NO UNDERLAY)

	Minimal overlap in cm	Sheltered site	Normal site	Exposed site
Zone 1	≥ 8	70	80	100
	≥ 7	80	90	110
Zone 2	≥ 8	70	90	110
	≥ 7	80	100	120
Zone 3	≥ 9	80	100	115
	≥ 8	90	110	125

These data are appropriate for rakes the ground plan of which does not exceed 8 m. Beyond 8 m, please consult us.

7 cm overlap = 10 cm gauge
8 cm overlap = 9.5 cm gauge
9 cm overlap = 9 cm gauge

Snow Protection: Revised 40.2 DTUs indicate: the protection against powder snow by the installation of a underlay screen must be specified in the specific documents of the market. Its implementation falls under DTU 40.29.

ZONES FOR THE APPLICATION OF MINIMUM PITCHES

France is divided up into 3 zones for the application of minimum pitches (with regard to wind/rain concomitance).

Note: the map below is indicative, only the definitions areas prevail.

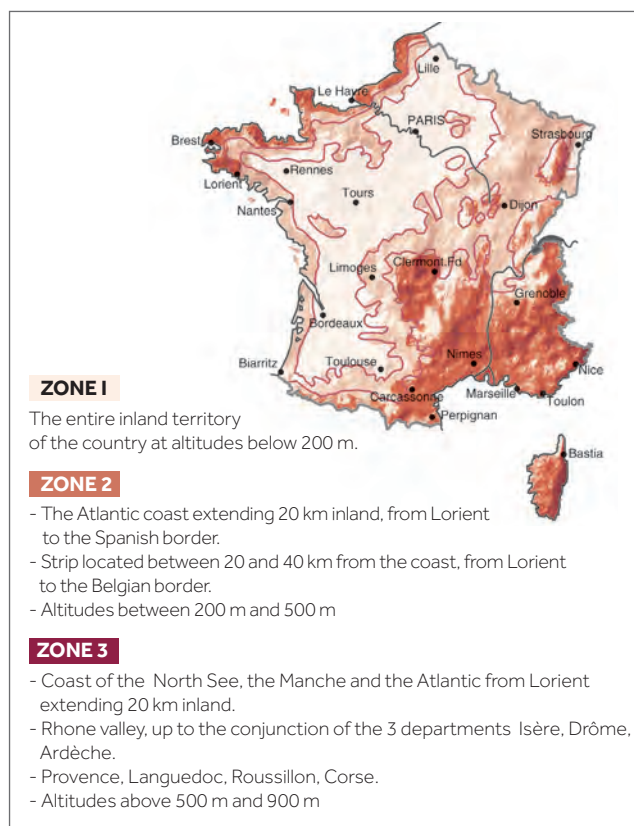

DEFINITION OF SITES ACCORDING TO THE DTU

SHELTERED SITUATION

Bottom of bowl bordered of hills on all its periphery and thus protected for all the directions of the wind.

NORMAL SITUATION

Plain or plateau of great extent that may have minor slopes of less than 10% slope (undulations, undulations).

EXPOSED SITUATION

In the vicinity of the sea: The coastline on a depth of about 5 km, the cliff tops, islands or narrow peninsulas.

Inside the country: The narrow valleys where the wind rushes, isolated and high mountains.

This division into three zones should not be confused with the division into Regions of Snow and Winds given in the rules NV.



BMI Group
Monier SAS

23-25, av. du Docteur Lannelongue
75014 Paris
Tel: 01 40 84 67 00
Fax: 01 40 84 67 01

Fabienne Alexandre - Export Manager

23-25, avenue du Docteur Lannelongue - 75014 Paris

T: 00 33 (0)1 40 84 66 98 - E: fabienne.alexandre@bmgigroup.com

Contact : export.fr@bmgigroup.com

monier.fr

BMI France, is part of the BMI Group, the largest manufacturer of flat and pitched roofing and waterproofing solutions throughout Europe with a significant presence in parts of Asia and Africa.

With 128 production facilities and operations in Europe, parts of Asia and Africa, the company brings more than 165 years of experience and employs over 9,500 employees.

BMI Group is headquartered in London.